



HYTEC 8902 USER MANUAL



DIN RAIL MOUNTING LEMO CONNECTION BLOCK AND TERMINATOR

Compatible with Hytec 8512 Industry Pack Scaler, Hytec 8002 IP Carrier Card and Hytec 8302 and 8352, 80mm and 160mm transition cards.

Also Compatible with analogue IP cards 8701, 8714, 8702 and 8715

**Hytec Electronics Ltd., Reading and Leicester,
England, UK.**

Tel: +44 (0)118 975 7770

Web: www.hytec-electronics.co.uk

HYTEC 8902 DIN Rail Mounting LEMO Connection Block and Terminator

Description

The 8902 is a cable converter and terminator. It comprises 20 single pole socket Lemo (00250) connectors and concentrates them into a single high density 50 way socket SCSI-2 type connector. Using the various linking options and optional external power supplies, it provides a range of termination options. The 50 way connector allows the use of freely available SCSI-2 cables to provide a short twisted pair cable into the standard VME64 and I.P. SCSI-2 type input 50 way connectors.

The unit clips onto either a standard Asymmetric or Top Hat DIN rail strip.

The Inputs can be terminated at 50Ω or 100Ω to Ground, +3.3Volts or +5 Volts (+3.3V and +5V require additional external power source). The terminated signals are made available to the VME64 or I.P. modules via a short SCSI-2 50 way cable plug to plug (normally 1 meter maximum).

The 8902 can be used at frequencies up to 100 MHz for both digital and analogue signals e.g. Scaler's and ADC's.

Circuit Description

A complete circuit diagram is available on the last page of this document. The circuit for a single LEMO input is shown in the figure below.

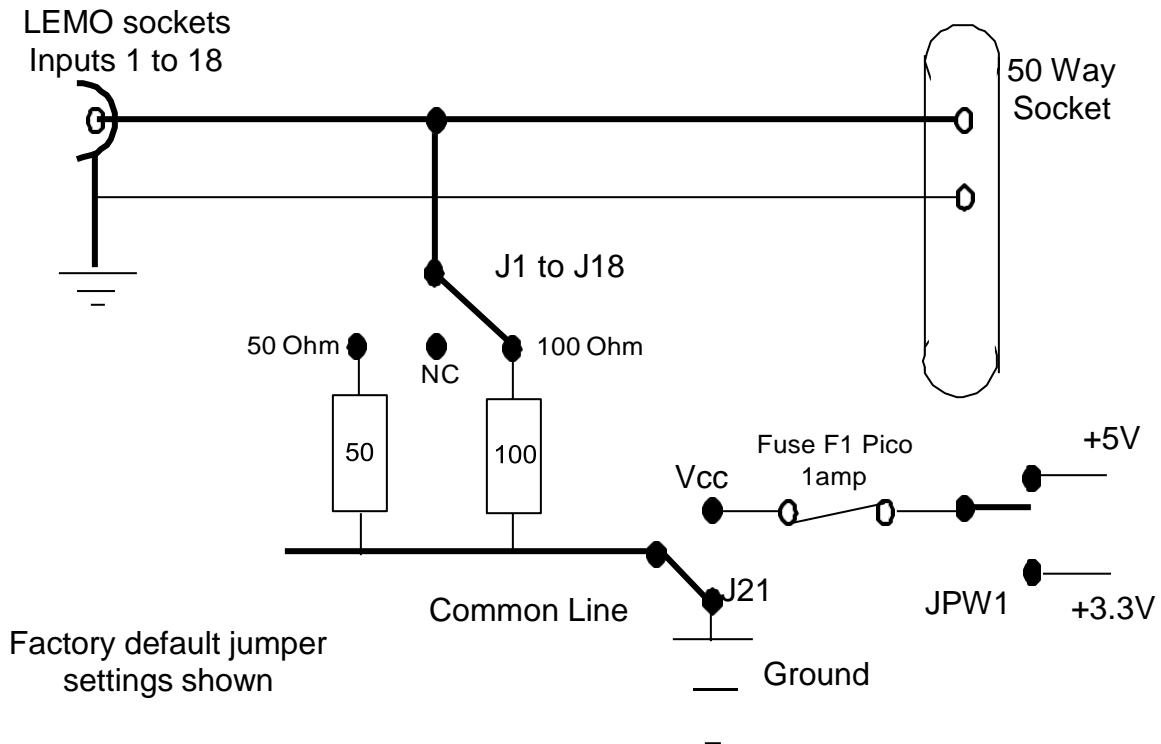

Each of the 16 signal inputs can be set to have no termination, 100 ohms termination or 50 ohms termination by selecting the positions of jumpers J1 to J16 in one of three positions. If 50 or 100ohms are selected they are connected to a common line that can be connected to ground, or by connecting an external power supply, to +5 Volts or +3.3Volts.

The 16 main signals inputs are marked 1 to16 and each has a three-way jumper marked J1 to J16. The jumper selects either 50 or 100 ohms termination. With the jumper connected at right angles to the NC pin, there is no termination resistor selection.

The factory default setting is for 100 ohms termination connected to ground.

Note: Selecting 50 ohms termination and +5V Vcc should be avoided due to excessive currents.

All jumpers have a single jumper and multiple pins, the options are clearly marked on the PCB. Connecting the appropriate pins makes the jumper selection.

Jumper J21 selects either a ground connection (GND) or a voltage (+Vcc). If active termination is required then the appropriate voltage must be supplied via CON1. The power connection pattern is clearly marked on the PCB (0V 0V +3.3 +5V). The power is passed on via a fuse F1. (Plug in type PICO fuse 1 amp made by Tracor). A diode is fitted to protect against accidental power reversal (if the fuse blows, check that the power connection to CON1 is correct).

Jumper JPW1 selects either the +3.3V of +5V supply connection.

Note: a single voltage, selected via jumper JPW1, powers all signal terminations. JPW1 is located next to CON1. as +3.3 volts (Standard) or +5 volts which is clearly marked on PCB. The external power supply, if needed, need only be a single voltage type.

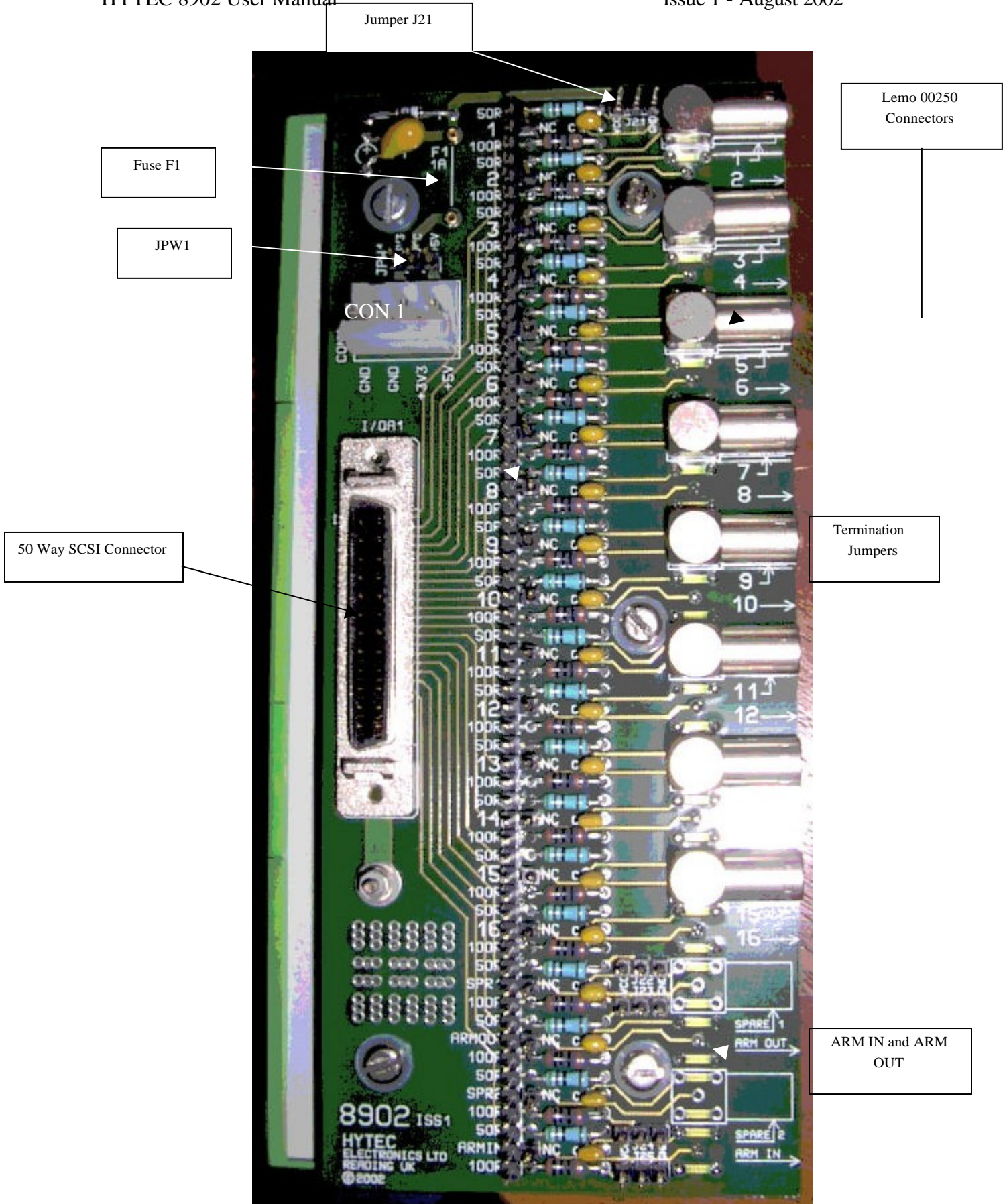

J1 to J16 jumper selection positions



With the jumper mounted in the centre of the channel number, horizontally = No connection to the termination resistor



100R o

This pattern is repeated on all of the 16 main signal inputs.

Signal Translation

Lemo cable signals to single 50-way SCSI cable translation
(See 8902 Iss. 1 circuit diagram)

Connections

LEMO SOCKET NUMBER	50 Way SCSI-2 Socket – Signal Pin No	50 Way SCSI-2 Socket – Ground Pin No
Lemo 1	26	1
Lemo 2	27	2
Lemo 3	28	3
Lemo 4	29	4
Lemo 5	30	5
Lemo 6	31	6
Lemo 7	32	7
Lemo 8	33	8
Lemo 9	34	9
Lemo 10	35	10
Lemo 11	36	11
Lemo 12	37	12
Lemo 13	38	13
Lemo 14	39	14
Lemo 15	40	15
Lemo 16	41	16
Lemo ARM IN	45	20
Lemo ARM OUT	43	18
SPARE 1	42	17
SPARE 2	44	19

ARM IN and ARM OUT SIGNALS

There are two additional control signals available

ARM IN is connected to 50 way connector pin 45 with ground pin 20

ARM OUT is connected to 50 way connector pin 43 with ground pin 18.

SPARES

There are two spare Lemo positions on the PCB with LEMOs not fitted as standard. These can be fitted by special factory request or fitted later by the client.

SPARE 1 is pin 42 with ground pin 17.

SPARE 2 is 50 way pin 44 with ground pin 19

Jumpers for ARM IN, ARM OUT and SPARES.

All the four control pins have separate termination jumpers, and the additional individual power selection jumpers.

ARM IN uses J20 to select termination value (Selected as J1 to J16). Power is selected via J25.

ARM OUT uses J18 to select termination value (Selected as J1 to J16). Power is selected via J23.

SPARE 1 uses J17 to select termination value (Selected as J1 to J16). Power is selected via J22

SPARE 2 uses J19 to select termination value (Selected as J1 to J16). Power is selected via J24

Notes:

- 1) As Factory standard all terminations are set to 100 Ohms to ground. This is done so that a standard 5Volt TTL buffer output stage can drive the input. The Scaler inputs are 3.3 volt TTL.
- 2) If the signal driver stages can drive 50 ohms to ground, and there is at least a 2.2 Volt signal voltage at the terminator, then the 50-Ohm option will be better. The signals should be viewed with an oscilloscope to check for clean signals, on the full cable run, if they are poor or ringing, then the active termination mode could be appropriate. Try swapping the Jumper and selecting the best solution. The ARM signal (count ON/OFF or Inhibit ON /OFF) is the most critical signal.
- 3) Remember that if the input count signals have more than a 50nS ring they could be double counted by the Scaler.

Unit Dimensions

Length 160mm, Width 70 mm, Depth 70mm.